



External Shell Water Detector Fitting

This fitting is designed to accept the standard Shell Water Detector Capsule and Syringe, and to permit a sample to be drawn without leakage of fuel. It is field adjustable to accept different lengths of syringe.

Operating Procedure

Insert the syringe with SWD capsule into the fitting. The capsule pushes the internal valve into the bore of the cylinder and allows the flange of the syringe to engage in the slot provided in the fitting. With the syringe secure in the fitting, it can be easily operated to draw the required sample volume.

Adjustment

The fitting can be adjusted* to accept different length syringes. Typical syringes in common use are the Atlas straight flange type, Atlas curved flange type, and the Kigliss syringe, all of which can be accommodated by this unit.

Adjustment can be easily done in the field to suit the particular syringe type in use. Unless otherwise requested, the fitting is factory set for the older type Atlas syringe with the straight shoulder flange.

To adjust for another syringe type, unscrew the locking ring Item 14, and screw the upper body extension Item 13, either in or out, until the slot into which the shoulder flange of this syringe fits is in the correct position. The upper body extension Item 13, should then be held in this position whilst the locking ring Item 14, is retightened. It is recommended that the threads in the extension and lock ring can be completely cleaned, and secured using an appropriate thread sealant such as Loctite 222.

The slot will be in the correct position when the syringe flange is engaged in it, and the SWD capsule is causing the internal valve Item 8, to lift sufficiently to permit flow into the syringe.

Aljac external SWD fittings produced prior to January 1995 were not adjustable, and were designed to accommodate the Atlas syringe with the straight shoulder flange.

* Note

A special tool, Pt. No. 6007233215 may be purchased from Aljac Fuelling Components Ltd for this purpose.

Maintenance and Repair

Possible sources of leakage in the external SWD fitting are the various seals in the assembly, and these should be replaced as necessary using the appropriate bonded seals or O-Rings.

Spare parts, including O rings, should be obtained from Aljac Fuelling Components Ltd to ensure correct operation of the device.

Dis-assembly of the unit is done by unscrewing the set screw Item 26 to permit withdrawal of the upper body, taking care not to damage the upper body/lower body O-ring seal Item 24. With the upper body carefully moved, the valve piston Item 8, and its retaining spring Item 6, can be removed. The two sealing o-rings Item 10, and Item 11, can now be examined. The valve piston sealing O-ring Item, 9, can be removed using a non-metallic tool to ease it from its groove in the internal bore of the upper body.

Note – when the unit is fitted to the 20 litre Sampler, the lower body is replaced by a machined entry in the Sampler base casting.

Trouble Shooting

Problems likely to be encountered in service with this unit will almost certainly be due to damaged O-ring seals. It would be good practice to replace all O-rings in the unit when it is dismantled for any reason, and a complete O-ring kit is available from Aljac Fuelling Components Ltd.

Possible sources of leakage are as indicated below

- i) Leakage from lower body/connector (4 litre Sampler)

Change bonded seals Item 5

- ii) Leakage from valve, when not in use

Remove upper body and replace O-ring Item 9

- iii) Leakage from valve whilst drawing a sample

Remove upper body and replace O-rings Item 10 and Item 11

- iv) Leakage from upper/lower body connection (4 litre Sampler)
or from upper body/Sampler (20 litre Sampler)

Remove upper body and replace O-ring Item 24

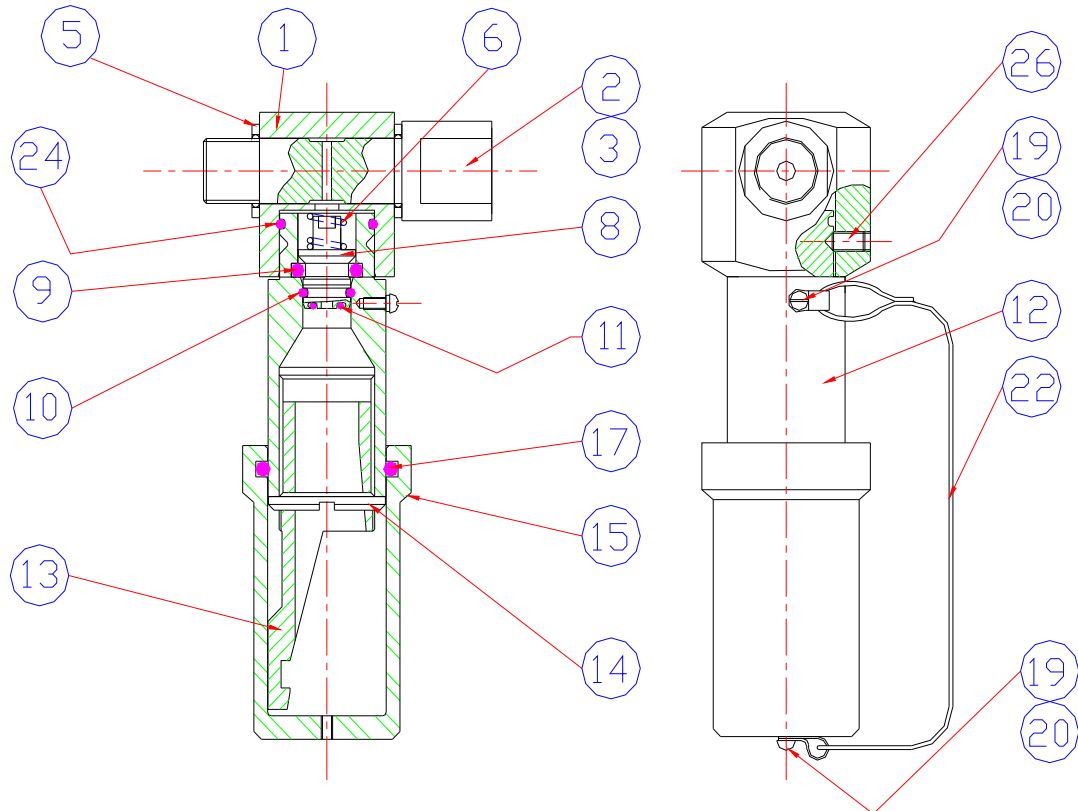

EXTERNAL SHELL WATER DETECTOR FITTING - PARTS LIST

| ITEM | DESCRIPTION | QTY | PART No. | ITEM | DESCRIPTION | QTY | PART No. |
|------|--------------------------------|-----|-----------|--|--------------------------------|-----|----------|
| 1 | BODY LOWER | 1 | 07233151 | 14 | UPPER BODY LOCK-RING | 1 | 07233221 |
| 2 | CONNECTOR - BSP | 1 | 07233152 | 15 | CAP | 1 | 07233192 |
| 3 | CONNECTOR - NPT | 1 | 07233189 | 17 | 'O' RING 9BS 1806-218 VITON A) | 1 | 07233160 |
| 5 | BONDED SEAL | 2 | 07233153 | 19 | SCREW. SS. M3x6mm | 1 | 07233162 |
| 6 | SPRING | 1 | 07233257 | 20 | WASHER. SS. M3 | 1 | 07233222 |
| 8 | VALVE PISTON | 1 | 07233155 | 22 | RETAINING WIRE | 1 | 07233201 |
| 9 | 'O' RING (BS 1806-206 VITON A) | 1 | 07233156 | 24 | 'O' RING (BS 1806-020 VITON A) | 1 | 07233164 |
| 10 | 'O' RING (BS 1806-012 VITON A) | 1 | 07233216* | 26 | SET SCREW. M5x8mm | 1 | 07233223 |
| 11 | 'O' RING (BS 1806-009 VITON A) | 1 | 07233158 | * THE EARLIER, NON-ADJUSTABLE EXTERNAL SWD FITTING Pt nD. 07233170, PRODUCED PRIOR TO JANUARY 1995, HAD AN 'O' RING TO BS 1806-109 VITON A | | | |
| 12 | UPPER BODY | 1 | 07233219 | | | | |
| 13 | UPPER BODY EXTENSION | 1 | 07233220 | | | | |