

### External Hydrokit Fitting

This fitting is designed to accept the standard Velcon Hydrokit test-tube, and to permit a sample of fuel to be drawn into the test-tube and checked for the presence of water, without leakage of fuel.

#### Operating Procedure

Insert a new Velcon Hydrokit Test-Tube into the fitting. The force necessary to push the needle in the fitting, through the rubber bung in the Test-Tube, is sufficient to open the internal valve and permit fuel to be drawn into the Test-Tube. After the fuel sample has been drawn, the Test-Tube should be carefully withdrawn, when the internal valve will close and stop the flow of fuel.

No adjustment of the device is necessary. However, it is possible that the rubber bung in the Test-Tube may remain impaled on the needle when the Test-Tube is removed and after the test sample has been taken. The rubber bung can be easily removed by accessing it through the slot in the side of the upper body.

#### Maintenance and Repair

The needle Item 14, will have to be replaced occasionally, as it may bend after some use, and may even fracture. It may be replaced without dismantling the device. By slackening the small grub screw Item 18, accessed through the slot in the upper body, the damaged needle can be unscrewed and replaced by a new needle.

Possible sources of leakage in the external Hydrokit fitting are the various seals in the assembly, and these should be replaced as necessary using the appropriate bonded seals or O-rings.

It should be noted that although the O-rings are standard British Standard (BS) O-rings, that used in the internal valve piston Item 10 is a specially selected close tolerance O-ring. As a result, spare O-rings should be obtained from Aljac Fuelling Components Ltd to ensure correct operation of the device. It would be good practice to replace all O-rings in the unit when it is dismantled for any reason and a complete O-ring kit is available from Aljac Fuelling Components Ltd.

Dismantling of the fitting is achieved by unscrewing the set screw Item 25, to permit withdrawal of the upper body Item 12, taking care not to damage the upper body/lower body O-ring seal Item 13. With the upper body carefully removed, the valve piston Item 8, and its retaining Spring Item 6, can be removed. The sealing O-ring Item 10 can now be examined. The valve piston sealing O-ring Item 9, can be removed using a non-metallic tool to ease it from its groove in the internal bore of the upper body.

Note – when the unit is fitted to the 20 litre Sampler, the lower body is replaced by a machined entry in the Sampler base casting.

## Trouble Shooting

i) Leakage from lower body/connector (4 litre Sampler)

Change bonded seals Item 5

ii) Leakage from valve, when not in use

Remove upper body and replace O-ring Item 9

iii) Leakage from valve whilst drawing a sample

Remove upper body and replace O-ring Item 10

iv) Leakage from upper/lower body connection (4 litre Sampler) or from upper body/Sampler (20 litre Sampler)

Remove upper body and replace O-ring Item 13

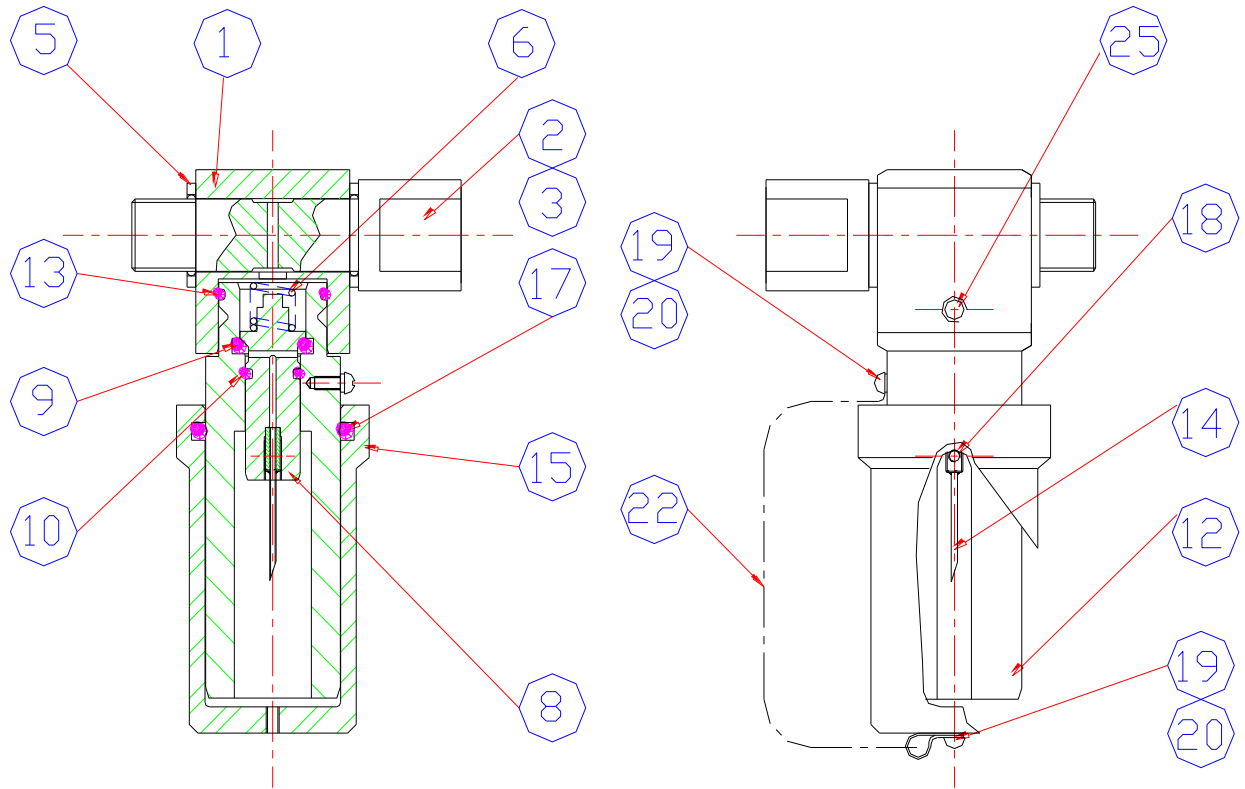

EXTERNAL HYDROKIT FITTING - PARTS LIST

ITEM	DESCRIPTION	QTY	PART No.	ITEM	DESCRIPTION	QTY	PART No.
1	BODY LOWER	1	07233151	13	'O' RING (BS 1806-020 VITON A)	1	07233164
2	CONNECTOR - BSP	1	07233152	14	NEEDLE	1	07233210
3	CONNECTOR - NPT	1	07233189	15	CAP	1	07233161
5	BONDED SEAL	2	07233153	17	'O' RING (BS 1806-218 VITON A)	1	07233160
6	SPRING	1	07233218	18	GRUB SCREW, S.S. M3x6mm	1	07233224
8	VALVE PISTON	1	07233209	19	SCREW, SS. M3x6mm	1	07233162
9	'O' RING (BS 1806-206 VITON A)	1	07233156	20	WASHER, SS. M3	1	07233222
10	'O' RING (BS 1806-012 VITON A)	1	07233216	22	RETAINING WIRE	1	07233201
12	UPPER BODY	1	07233208	25	SET SCREW, M5x8mm	1	07233223